

Commercial Marine Generator Set

Generator Features

- IMO Tier III compliant
- Selective Catalytic Reduction (SCR) system to meet IMO Tier III No_x levels
- Reductant (DEF) buffer tank (30 L)
- Permanent magnet-excited alternator
- Sealed double-bearing alternator
- Frame-in-frame skid design
- Class H insulation with EG43 marinization treatment
- Isolated ground
- Voltage regulation of 2%
- Frequency regulation of 0.5%

Optional Agency Approvals

- Det Norske Veritas- Germanischer Lloyd (DNV- GL)
- China Classification Society (CCS)



Generator Weights and Dimensions

Generator Set			
Keel Cooled			
Weight, kg (lb.)			
Wet	3524	(7770)	
Dry	3475	(7660)	
Heat Exchanger Cooled			
Weight, kg (lb.)			
Wet	3629	(8000)	
Dry	3579	(7890)	
Length, mm (in.)	3358	(132.2)	
Width, mm (in.)	1292	(50.8)	
Height, mm (in.)	1998	(78.7)	

See the drawings on the last page for detailed dimensions.

Generator Ratings (Prime)

Model						
Generator (Alternator)	Voltage	Hz	Ph	Amps	Rated kW/kVA	
350EOZCS (ECO40-3S)	120/208	60	3	1214	350/438	
	120/240	60	3	1052	350/438	
	127/220	60	3	1148	350/438	
	139/240	60	3	1052	350/438	
	220/380	60	3	665	350/438	
	277/480	60	3	526	350/438	
300EFOZCS (ECO40-3S)	110/190	50	3	1140	300/375	
	110/220	50	3	984	300/375	
	220/380	50	3	570	300/375	
	230/400	50	3	541	300/375	
	240/415	50	3	522	300/375	

RATINGS: Ratings per ISO 3046, ISO 8528-1, and Kohler ISO rating guideline 2.14. Obtain technical information bulletin (TIB-101) on ratings guidelines for complete ratings definitions.

Availability is subject to change without notice. Kohler Co. reserves the right to change the design or specifications without notice and without any obligation or liability whatsoever. Contact your local Kohler generator set distributor for availability.

10% overload capacity one hour in twelve hours.

Application Data

Engine

Engine Specifications	60 Hz	50 Hz
Type	4-cycle	
Number of cylinders	6, inline	
Firing order	1-5-3-6-2-4	
Aspiration	Turbocharged with closed crankcase ventilation	
Displacement, L (cu. in.)	12.7 (775)	
Bore and stroke, mm (in.)	130 x 160 (5.12 x 6.30)	
Compression ratio	17.3:1	
Combustion system	Direct injection	
Rated rpm	1800	1500
Maximum power at rated rpm, HP	504	433
Crankshaft material	Alloy steel with hardened & polished bearing surfaces	
Connecting rod material	I-section pressed forgings & alloy steel	
Governor type	Electronically controlled	

Engine Electrical

Engine Electrical System	60 Hz	50 Hz
Battery, voltage	24-volt	
Battery, charging alternator	28 V, 100 amp, 2 pole	
Battery, recommendation	160 Ah, 800 CCA	
Starter motor	24 V, 2 pole, 7.0 kW	

Cooling

Cooling System	60 Hz	50 Hz
Capacity, L (U.S. qt.) (approx.) Engine only:	HX* KC*	40 (42.3) 20 (21.1)
Cooling type	Heat exchanger or keel cooled	
Seawater pump type	HX*	Gear driven 12 blade impeller
Seawater pump suction lift, maximum, m (ft.)	HX*	3.0 (10.0)
Heat rejected to cooling water at rated kW, kW (Btu/min.)	HX* KC*	242 (13775) 210 (11953)
jacket water: charge air cooler:	KC* KC*	194 (11042) 177 (10074) 48 (2732) 32 (1821)
Engine water pump flow, at max. restriction, Lpm (gpm)		363 (96) 304 (80)
Seawater pump flow, at max. restriction, Lpm (gpm)	HX*	250 (66) 215 (57)
Charge air cooler pump flow, at max. restriction, Lpm (gpm)	KC*	230 (61) 190 (50)

Fuel

Fuel System	60 Hz	50 Hz
Fuel recommendation	Diesel fuel specified to EN 590	
Fuel pump priming	Manual or optional suction tool	
Maximum recommended fuel lift, m (ft.)	3.0 (10)	

* **HX** = Heat Exchanger and **KC** = Keel Cooled

Lubrication

Lubricating System	60 Hz	50 Hz
Oil pan capacity with filter, L (U.S. qt.) min.- max.	28- 34 (29.6- 35.9)	
Type	Pressure	

Operation Requirements

Air Requirements	60 Hz	50 Hz
Engine combustion air requirements, kg/min.	HX* KC*	29 22
Max. air intake restriction, kPa (in. H ₂ O)	6.5 (26.1)	
Cooling air required for generator set, m ³ /min. (cfm)	64.8 (2288)	54 (1907)
Exhaust flow, kg/min.	30	23
Exhaust temp., °C (°F)	468 (874)	494 (921)
Max. allowable total exhaust backpressure (measured at the turbo), kPa (in. H ₂ O)	12.7 (51.0)	11.8 (47.4)
Max. allowable backpressure for customer additional piping, post after treatment, kPa (in. H ₂ O)	5 (20)	

Fuel Consumption	60 Hz	50 Hz
Diesel, Lph (gph) at % load		
100%	89.34(23.6)	76.28(20.2)
75%	66.89(17.7)	55.99(14.8)
50%	50.38(13.3)	40.69(10.7)
25%	36.72 (9.7)	23.85 (6.3)

Engine Features

- Low oil pressure shutdown
- High water temperature shutdown
- Loss of coolant shutdown
- Overcrank shutdown
- Belt guard
- Water cooled oil cooler
- Disposable, centrifugal oil filter
- Oil drain valve with skid mounted drain
- Exhaust routing valve

Controller Features

- A graphical display and pushbutton/rotary selector dial provide easy, local data access.
- Measurements are selectable in metric or English units.
- The controller supports Modbus® protocol with serial bus (RS-485) or Ethernet networks.
- Scrolling display shows critical data at a glance.
- Graphical display of power metering (kW, kVA, V, I, PF, and VAR).
- Integrated hybrid voltage regulator providing ±0.5% regulation.
- Built-in alternator thermal overload protection.

Modbus® is a registered trademark of Schneider Electric.

Decision-Maker® 3500 Paralleling Controller



Provides advanced control, system monitoring, and system diagnostics for optimum performance and compatibility. The Decision-Maker® 3500 controller uses a patented hybrid voltage regulator and unique software logic to manage alternator thermal overload protection features normally requiring additional hardware. Additional features include:

- **AC Output Voltage Regulator Adjustment.** The voltage adjustment provides a maximum adjustment of $\pm 10\%$ of the system voltage.
- **Alarm Silence.** The controller can be set up to silence the alarm horn only when in the AUTO mode for NFPA-110 application or Always for user convenience.
- **Alternator Protection.** The controller provides generator set overload and short circuit protection matched to each alternator for the particular voltage/phase configuration.
- **Automatic Restart.** The controller automatic restart feature initiates the start routine and re crank after a failed start attempt.
- **Cyclic Cranking.** The controller has programmable cyclic cranking.
- **ECM Diagnostics.** The controller displays engine ECM fault code descriptions to help in engine troubleshooting.
- **Engine Start Aid.** The configurable starting aid feature provides customized control for an optional engine starting aid.
- **Event Logging.** The controller keeps a record (up to 1000 entries) for warning and shutdown faults. This fault information becomes a stored record of system events and can be reset.
- **Historical Data Logging.** Total number of successful starts of the generator is recorded and displayed.
- **Integrated Hybrid Voltage Regulator.** The voltage regulator provides $\pm 0.5\%$ no-load to full-load RMS voltage regulation with three-phase sensing.
- **Lamp Test.** Press the alarm silence/lamp test button to verify functionality of the indicator lights.
- **LCD Display.** Adjustable contrast for improving visibility.
- **Measurement Units.** The controller provides selection of English or metric displays.
- **Power Metering.** Controller graphical display provides voltage, current, power factor, kW, kVA, and kVAR.
- **Programming Access (USB).** Provides software upgrades and diagnostics with PC software tools.
- **Remote Reset.** The remote reset function supports acknowledging and resetting faults and allows restarting of the generator set without going to the master control switch off/reset position.
- **Run Time Hourmeter.** The generator set run time is displayed.
- **Time Delay Engine Cooldown (TDEC).** The TDEC provides a time delay before the generator set shuts down.
- **Time Delay Engine Start (TDES).** The TDES provides a time delay before the generator set starts.
- **Voltage Selection Menu.** This menu provides the capability to switch the generator output voltage. NOTE: Generator set output leads may require reconnection.
- **Paralleling Functions:**
 - Bus sensing
 - First on logic
 - Synchronizing
 - Communication based isochronous load sharing
 - Droop load sharing
 - External controlled load sharing via analog bias signals

Alternator Specifications

Alternator Specifications

Type	4-pole, rotating-field
Exciter type	Brushless, permanent-magnet
Number of leads	12
Voltage regulator	Solid state, volts/Hz
Insulation: NEMA MG1-1.66	
Material	Class H
Temperature rise	115°C
Bearing: number, type	2, sealed (front and rear)
Coupling	Flexible rubber disc
Amortisseur windings	Full
One-step load acceptance per NFPA 110	
Peak motor starting kVA:	100% of rating
480 V, 415 V ECO40-3S	(35% dip for voltages below)

Alternator Features

- The generator complies with NEMA, IEEE, and ANSI standards for temperature rise.
- The alternator uses a permanent-magnet excitation system.
- The alternator has a two-thirds pitch, skewed stator.
- The generator has a solid-state, volts-per-hertz voltage regulator.
- Brushless, rotating-field alternator.
- Grey marinization treatment (EG43). Grey varnish is a high temperature insulating enamel that forms a tough and flexible film with excellent moisture and chemical protection. It is water and oil proof and also protects windings from abrasion.
- The generator sustains short-circuit current up to 300% of the rated current for up to 10 seconds.

DEF Buffer Tank Specifications

DEF buffer tank capacity, L (gal.)	30 (7.9)	
Recommended DEF		
With 32.5% by weight of urea	31.8-33.2% according to ISO 22241	
With 40% by weight of urea	39-40% according to ISO 18611	
DEF consumption, Lph (gph) at % load	60 Hz	50 Hz
100%	6.79 (1.8)	6.76 (1.8)
75%	6.10 (1.6)	4.76 (1.3)
50%	4.25 (1.1)	2.89 (0.8)
25%	2.32 (0.6)	1.76 (0.5)

Accessories/Options

- Remote digital display
- Remote connection/extension harness
- Circuit breakers
- Oil level indicator (high/low)
- Low coolant level indicator
- Flexible fuel lines
- Generator heater
- 15-relay dry contact
- Run relay
- Block heater
- Duplex fuel water separator filter
- DEF feed pump extension harness

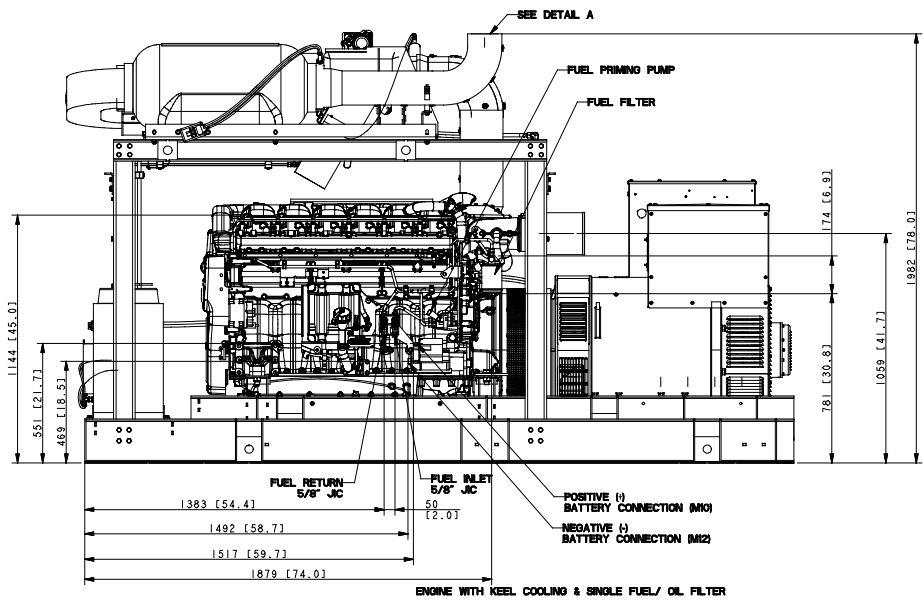
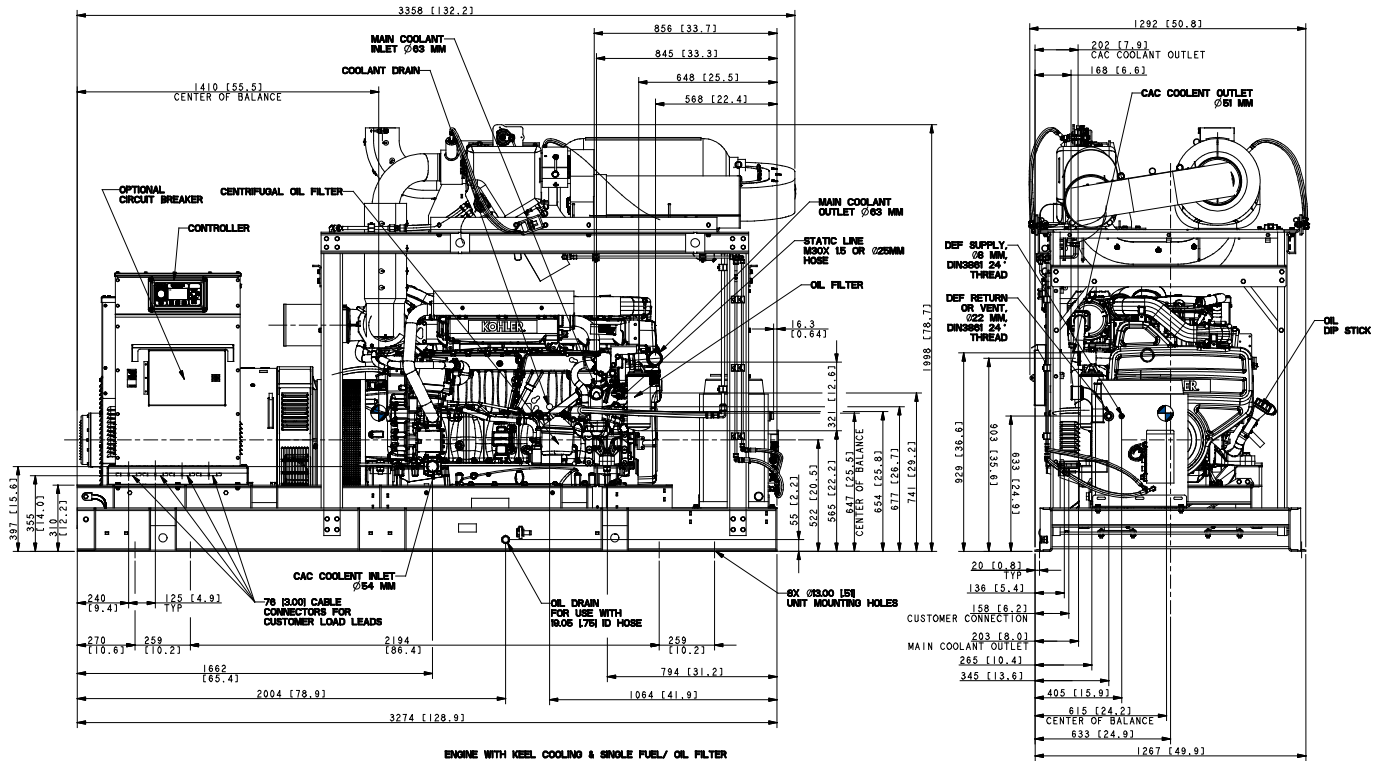

ADV-9113-A

DISTRIBUTED BY:

NOTE: Dimensions are shown in mm [in.].
 NOTE: This drawing is provided for reference only and is not intended for installation planning. Contact your local distributor for more detailed information.